







POOLEX

O'SPA FLOW



-  Manuel d'installation et d'utilisation
-  Installation and user manual
-  Manual de usuario y instalación
-  Manuale d'installazione e d'uso
-  Installations und Gebrauchsanleitung
-  Installatie en gebruikershandleiding

 *Cher client,*

Nous vous remercions pour votre achat et pour la confiance que vous accordez à nos produits.

Nos produits sont le résultat d'années de recherche dans le domaine de la conception et de la production de pompe à chaleur pour piscine et spa. Notre ambition, vous fournir un produit de qualité aux performances hors normes.

Nous avons réalisé ce manuel avec le plus grand soin afin que vous puissiez tirer le meilleur de votre pompe à chaleur Poolex.

 *Dear customer,*

Thank you for your purchase and your trust in our products.

Our products are the result of years of research in the design and manufacture of heat pumps for pools. Our goal is to deliver high-quality products with exceptional performance.

We took great care to put together this manual so you can get the most out of your Poolex heat pump.

 *Estimado(a) cliente,*

Agradecemos que haya comprado este producto y que haya confiado en nuestra empresa.

Nuestros productos son el fruto de años de investigación en el sector del diseño y de la producción de bombas de calor para las piscinas. Nuestro objetivo es ofrecerle un producto de calidad con un rendimiento excepcional.

Hemos redactado este manual de tal forma que podrá aprovechar al máximo su Poolex bomba de calor.

 *Gentile cliente,*

La ringraziamo per il Suo acquisto e per la sua fiducia nei nostri prodotti.

Essi sono il risultato di anni di ricerche nella progettazione e produzione di pompe di calore per piscine. Il nostro scopo è di fornir. Le un prodotto di qualità con prestazioni fuori dal comune.

Abbiamo preparato questo manuale con la massima cura affinché Lei possa sfruttare al meglio la Sua pompa di calore Poolex.

 *Sehr geehrter Kunde,*

Vielen Dank für Ihren Kauf und das damit verbundene Vertrauen in unsere Produkte.

Unsere Produkte sind das Ergebnis einer jahrelangen Forschungsarbeit auf dem Gebiet der Konstruktion und Fertigung von Schwimmbecken-Wärmepumpen. Wir haben den Anspruch, Ihnen ein qualitativ hochwertiges Produkt mit hervorragenden Leistungseigenschaften zu liefern.

Die vorliegende Anleitung wurde mit größter Sorgfalt erstellt und soll Ihnen dabei helfen, die Vorzüge Ihrer Poolex-Wärmepumpe bestmöglich zu nutzen.

 *Geachte klant,*

Bedankt voor uw aankoop en uw vertrouwen in onze producten.

Ons doel is om u een uitzonderlijk goed prester- end kwaliteitsproduct te leveren. Het is onze ambitie om u een kwaliteitsvol product met uitstekende prestaties te leveren.

We hebben deze handleiding met de grootste zorg samengesteld, zodat u het maximale uit uw Poolex-warmtepomp kunt halen.



Manuel d'installation et d'utilisation

FR



Installation and user manual

EN



Manual de usuario y instalación

ES



Manuale d'installazione e d'uso

IT



Installations und Gebrauchsanleitung

DE



Installatie en gebruikershandleiding

NL

WARNING



R32 *This heat pump contains a flammable refrigerant R32. Any intervention on the refrigerant circuit is prohibited without a valid authorization. Before working on the refrigerant circuit, the following precautions are necessary for safe work.*

Only persons authorized by an accredited agency certifying their competence to handle refrigerants in compliance with sector legislation should work on refrigerant circuits.

Servicing shall be performed only as recommended by the manufacturer.

Any person who is involved with working on or breaking into a refrigerant circuit should hold a current valid certificate from an industry-accredited assessment authority, which authorises their competence to handle refrigerants safely in accordance with an industry recognised assessment specification.

Servicing shall only be performed as recommended by the equipment manufacturer. Maintenance and repair requiring the assistance of other skilled personnel shall be carried out under the supervision of the person competent in the use of flammable refrigerants.

Signs for similar appliances used in a work area are generally addressed by local regulations and give the minimum requirements for the provision of safety and/or health signs for a work location.

All required signs are to be maintained and employers should ensure that employees receive suitable and sufficient instruction and training on the meaning of appropriate safety signs and the actions that need to be taken in connection with these signs.

The effectiveness of signs should not be diminished by too many signs being placed together.

Any pictograms used should be as simple as possible and contain only essential details.

The disposal of equipment using flammable refrigerants should be in accordance with local national regulations.

The storage of the appliance should be in accordance with the applicable regulations or instructions, whichever is more stringent.

Storage package protection should be constructed in such a way that mechanical damage to the equipment inside the package will not cause a leak of the refrigerant charge. The maximum number of pieces of equipment permitted to be stored together will be determined by local regulations.

1. Checks to the area

Prior to beginning work on systems containing flammable refrigerants, safety checks are necessary to ensure that the risk of ignition is minimised. For repair to the refrigerating system, the following precautions shall be complied with prior to conducting work on the system.

2. Work procedure

The work must be carried out according to a controlled procedure, in order to minimize the risk of presence of flammable gases or vapors during the execution of the works.

3. General work area

All persons in the area must be informed of the nature of the work in progress. Avoid working in a confined area. The area around the work area should be divided, secured and special attention should be paid to nearby sources of flame or heat.

4. Verification of the presence of refrigerant

The area should be checked with a suitable refrigerant detector before and during work to ensure that there is no potentially flammable gas. Make sure that the leak detection equipment used is suitable for flammable refrigerants, i.e. it does not produce sparks, is properly sealed or has internal safety.

5. Presence of fire extinguisher

If hot work is to be performed on the refrigeration equipment or any associated part, appropriate fire extinguishing equipment must be available. Install a dry powder or CO₂ fire extinguisher near the work area.

6. No source of flame, heat or spark

It is totally forbidden to use a source of heat, flame or spark in the direct vicinity of one or more parts or pipes containing or having contained a flammable refrigerant. All sources of ignition, including smoking, must be sufficiently far from the place of installation, repair, removal and disposal, during which time a flammable refrigerant may be released into the surrounding area. Before starting work, the environment of the equipment should be checked to ensure that there is no risk of flammability. «No smoking» signs must be posted.

WARNING

7. Ventilated area

Make sure the area is in the open air or is properly ventilated before working on the system or performing hot work. Some ventilation must be maintained during the duration of the work.

8. Controls of refrigeration equipment

When electrical components are replaced, they must be suitable for the intended purpose and the appropriate specifications. Only the parts of the manufacturer can be used. If in doubt, consult the technical service of the manufacturer.

The following controls should be applied to installations using flammable refrigerants:

- *The size of the load is in accordance with the size of the room in which the rooms containing the refrigerant are installed;*
- *Ventilation and air vents work properly and are not obstructed;*
- *If an indirect refrigeration circuit is used, the secondary circuit must also be checked.*
- *The marking on the equipment remains visible and legible. Illegible marks and signs must be corrected;*
- *Refrigeration pipes or components are installed in a position where they are unlikely to be exposed to a substance that could corrode components containing refrigerant*

9. Verification of electrical appliances

Repair and maintenance of electrical components must include initial safety checks and component inspection procedures. If there is a defect that could compromise safety, no power supply should be connected to the circuit until the problem is resolved.

Initial security checks must include:

- *That the capacitors are discharged: this must be done in a safe way to avoid the possibility of sparks;*
- *No electrical components or wiring are exposed during loading, recovery or purging of the refrigerant gas system;*
- *There is continuity of grounding.*

10. Initial safety checks shall include

- *that capacitors are discharged: this shall be done in a safe manner to avoid possibility of sparking;*
- *that no live electrical components and wiring are exposed while charging, recovering or purging the system;*
- *that there is continuity of earth bonding.*

11. Repairs to sealed components

During repairs to sealed component, all electrical supplies shall be disconnected from the equipment being worked upon prior to any removal of sealed covers, etc. If it is absolutely necessary to have an electrical supply to equipment during servicing, then a permanently operating form of leak detection shall be located at the most critical point to warn of a potentially hazardous situation.

Particular attention shall be paid to the following to ensure that by working on electrical components, the casing is not altered in such a way that the level of protection is affected. This shall include damage to cables, excessive number of connections, terminals not made to original specification, damage to seals, incorrect fitting of glands, etc.

Ensure that apparatus is mounted securely.

Ensure that seals or sealing materials have not degraded such that they no longer serve the purpose of preventing the ingress of flammable atmospheres. Replacement parts shall be in accordance with the manufacturer's specifications.

NOTE The use of silicon sealant may inhibit the effectiveness of some types of leak detection equipment. Intrinsically safe components do not have to be isolated prior to working on them.

12. Repair to intrinsically safe components

Do not apply any permanent inductive or capacitance loads to the circuit without ensuring that this will not exceed the permissible voltage and current permitted for the equipment in use.

Intrinsically safe components are the only types that can be worked on while live in the presence of a flammable atmosphere. The test apparatus shall be at the correct rating.

Replace components only with parts specified by the manufacturer. Other parts may result in the ignition of refrigerant in the atmosphere from a leak.

WARNING

13. Cabling

Check that cabling will not be subject to wear, corrosion, excessive pressure, vibration, sharp edges or any other adverse environmental effects. The check shall also take into account the effects of ageing or continual vibration from sources such as compressors or fans.

14. Detection of flammable refrigerants

Under no circumstances shall potential sources of ignition be used in the searching for or detection of refrigerant leaks. A halide torch (or any other detector using a naked flame) shall not be used.

15. Leak detection methods

The following leak detection methods are deemed acceptable for systems containing flammable refrigerants. Electronic leak detectors shall be used to detect flammable refrigerants, but the sensitivity may not be adequate, or may need re-calibration. (Detection equipment shall be calibrated in a refrigerant-free area. Ensure that the detector is not a potential source of ignition and is suitable for the refrigerant used. Leak detection equipment shall be set at a percentage of the LFL of the refrigerant and shall be calibrated to the refrigerant employed and the appropriate percentage of gas (25% maximum) is confirmed.

Leak detection fluids are suitable for use with most refrigerants but the use of detergents containing chlorine shall be avoided as the chlorine may react with the refrigerant and corrode the copper pipe-work.

If a leak is suspected, all naked flames shall be removed/extinguished.

If a leakage of refrigerant is found which requires brazing, all of the refrigerant shall be recovered from the system, or isolated (by means of shut off valves) in a part of the system remote from the leak. Oxygen free nitrogen (OFN) shall then be purged through the system both before and during the brazing process.

16. Removal and evacuation

When breaking into the refrigerant circuit to make repairs - or for any other purpose - conventional procedures shall be used. However, it is important that best practice is followed since flammability is a consideration. The following procedure shall be adhered to:

1. remove refrigerant;
2. purge the circuit with inert gas;
3. evacuate;
4. purge again with inert gas;
5. open the circuit by cutting or brazing.

The refrigerant charge shall be recovered into the correct recovery cylinders. The system shall be "flushed" with OFN to render the unit safe. This process may need to be repeated several times. Compressed air or oxygen shall not be used for this task.

Flushing shall be achieved by breaking the vacuum in the system with OFN and continuing to fill until the working pressure is achieved, then venting to atmosphere, and finally pulling down to a vacuum. This process shall be repeated until no refrigerant is within the system. When the final OFN charge is used, the system shall be vented down to atmospheric pressure to enable work to take place. This operation is absolutely vital if brazing operations on the pipe - work are to take place.

Ensure that the outlet for the vacuum pump is not close to any ignition sources and there is ventilation available.

17. Charging procedures

In addition to conventional charging procedures, the following requirements shall be followed.

- Ensure that contamination of different refrigerant does not occur when using charging equipment. Hoses or lines shall be as short as possible to minimize the amount of refrigerant contained in them.
- Cylinders shall be kept upright.
- Ensure that the refrigeration system is earthed prior to charging the system with refrigerant.
- Label the system when charging is complete (if not already).
- Extreme care shall be taken not to overfill the refrigeration system.

Prior to recharging the system it shall be pressure tested with OFN. The system shall be tested on completion of charging but prior to commissioning. A follow up leak test shall be carried out prior to leaving the site.

WARNING

18. Decommissioning

Before carrying out this procedure, it is essential that the technician is completely familiar with the equipment and all its detail. It is recommended good practice that all refrigerants are recovered safely. Prior to the task being carried out, an oil and refrigerant sample shall be taken in case analysis is required prior to re-use of reclaimed refrigerant. It is essential that electrical power is available before the task is commenced.

- a) Become familiar with the equipment and its operation.
- b) Isolate system electrically.
- c) Before attempting the procedure ensure that:
 - mechanical handling equipment is available, if required, for handling refrigerant cylinders:
 - all personal protective equipment is available and being used correctly
 - the recovery process is supervised at all times by a competent person;
 - recovery equipment and cylinders conform to the appropriate standards.
- d) Pump down refrigerant system, if possible.
- e) If a vacuum is not possible, make a manifold so that refrigerant can be removed from various parts of the system.
- f) Make sure that cylinder is situated on the scales before recovery takes place.
- g) Start the recovery machine and operate in accordance with manufacturers instructions.
- h) Do not overfill cylinders. (No more than 80 volume liquid charge).
- i) Do not exceed the maximum working pressure of the cylinder, even temporarily.
- j) When the cylinders have been filled correctly and the process completed, make sure that the cylinders and the equipment are removed from site promptly and all isolation valves on the equipment are closed off.
- k) Recovered refrigerant shall not be charged into another refrigeration system unless it has been cleaned and checked.

19. Labeling

Equipment shall be labeled stating that it has been de-commissioned and emptied of refrigerant. The label shall be dated and signed. Ensure that there are labels on the equipment stating the equipment contains flammable refrigerant.

20. Recovery

When removing refrigerant from a system, either for the servicing or decommissioning, it is recommended good practice that all refrigerants are removed safely.

When transferring refrigerant into cylinders, ensure that only appropriate refrigerant recovery cylinders are employed. Ensure that the correct number of cylinders for holding the total system charge are available. All cylinders to be used are designate for the recovered refrigerant and labeled for that refrigerant (i.e. special cylinders for the recovery of Refrigerant). Cylinders shall be complete with pressure relief valve and associated shut-off valves in good working order. Empty recovery cylinders are evacuated and, if possible, cooled before recovery occurs.

The recovery equipment shall be in good working order with a set of instructions concerning the equipment that is at hand and shall be suitable for the recovery of flammable refrigerants In addition, a set of calibrated weighing scales shall be available and in good working order Hoses shall be complete with leak-free disconnect couplings and in good condition. Before using the recovery machine, check that it is in satisfactory working order, has been properly maintained and that any associated electrical components are sealed to prevent ignition in the event of a refrigerant release. Consult manufacturer if in doubt.

The recovered refrigerant shall be returned to the refrigerant supplier in the correct recovery cylinder, and the relevant Waste Transfer Note arranged. Do not mix refrigerants in recovery nits and especially not in cylinders.

If compressors or compressor oils are to be removed, ensure that they have been evacuated to an acceptable level to make certain that flammable refrigerant does not remain within the lubricant. The evacuation process shall be carried out prior to returning the compressor to the suppliers. Only electric heating to the compressor body shall be employed to accelerate this process. When oil is drained from a system, it shall be carried out safety.

ACKNOWLEDGEMENTS

Dear customer,

Thank you for your purchase and your trust in our products.

Our products are the result of years of research in the design and manufacture of heat pumps for pools. Our goal is to deliver high-quality products with exceptional performance.

We took great care to put together this manual so you can get the most out of your Poolex heat pump.

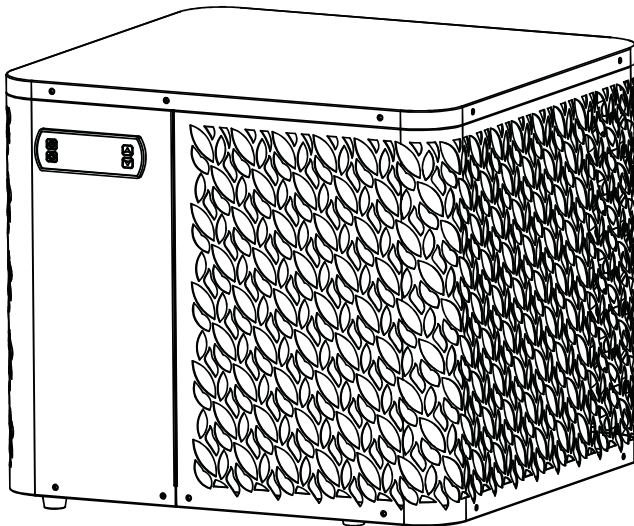



PLEASE READ CAREFULLY



These installation instructions form an integral part of the product. They must be provided to the installer and kept in a safe place by the user. If you lose this manual, please visit our website:

www.poolex.fr

The indications and warnings contained in this manual should be carefully read and understood as they provide important information regarding the safe handling and operation of the heat pump. Keep this manual handy for future reference.

Installation must be performed by a qualified professional in accordance with regulations in force and the manufacturer's instructions. Errors made during installation can cause physical injuries to people and animals, as well as mechanical damage for which the manufacturer shall not be held liable.

After unpacking the heat pump, please check the contents for any signs of damage.

Before plugging in the heat pump, ensure that the instructions provided in this manual are compatible with the actual installation conditions and do not exceed the maximum authorised limits for the product in question.

In the event of a defect and/or malfunction of the heat pump, electrical power must be shut off and no attempts to repair the fault should be made. Repairs must be carried out by an authorised technician using original spare parts. Non-compliance with the aforementioned clauses can negatively impact the safe operation of the heat pump.

In order to guarantee the efficiency and ensure the proper functioning of the heat pump, it must be regularly maintained in accordance with the instructions provided.

In the event the heat pump is sold or transferred to a third party, please ensure that all technical documentation is given to the new owner alongside the equipment.

This heat pump has been designed to only heat the water of a swimming pool. Any other use is considered inappropriate, incorrect and potentially dangerous.

All contractual and extra-contractual liability on the part of the manufacturer / distributor shall be considered null and void in the event of damage caused by errors in installation or operation, or due to non-compliance with the instructions provided in this manual, or the standards in force for the installation of equipment discussed in this document.

CONTENTS

1. General information	44
1.1 General terms and conditions of delivery.....	44
1.2 Safety instructions.....	44
1.3 Water treatment.....	45
2. Description	46
2.1 Package contents.....	46
2.2 General characteristics.....	46
2.3 Operating limits.....	46
2.4 Technical characteristics.....	47
2.5 Product dimensions.....	48
2.6 Exploded view.....	49
3. Installation	51
3.1 Location.....	51
3.2 Installation diagram.....	52
3.3 Hydraulic connection.....	52
3.4 Electrical connection.....	52
3.5 Operation.....	53
4. Use	54
4.1 Control panel.....	54
4.2 Heating / Cooling / Automatic mode.....	54
4.3 Heat pump operating mode selector.....	55
4.4 Functions overview.....	55
4.5 Using the SPA heater control relay.....	56
4.6 Downloading & installing the application «Poolex».....	57
4.7 Setting up the application.....	58
4.8 Pairing the heat pump.....	60
4.9 Controlling.....	61
4.10 Status values.....	63
4.11 Forced defrosting.....	63
4.12 Advanced settings.....	64
5. Maintenance and servicing	66
5.1 Maintenance, servicing and winterizing.....	66
6. Repairs	67
6.1 Breakdown and faults.....	67
7. Warranty	68
7.1 General terms and conditions of warranty.....	68

+ appendices at end of document

1. GENERAL INFORMATION

1.1 General terms and conditions of delivery

All products and packaging, even those delivered carriage paid, travel at the risk of the recipient.

Persons responsible for accepting delivery of the device must perform a visual inspection to make a note of any damage that may have occurred during transportation (refrigeration circuit, casing, electric box, frame). Any damage occurring during transportation must be noted by the recipient on the delivery receipt of the carrier, and confirmed by registered post sent to the carrier within 48 hours.

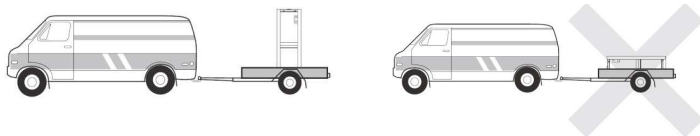

The device must be stored and transported upright at all times, on a pallet, and in its original packaging. If the device has been transported in a horizontal position, please wait at least 24 hours prior to connecting it.

1.2 Safety instructions



WARNING: Please read carefully all safety instructions before using the device. As the instructions noted in this document are essential to your safety, please respect them carefully.

Installation and maintenance

Only a qualified person may undertake installation, start-up, servicing and repairs, in compliance with current standards.

Before operating or undertaking any work on the device (installation, start-up, use, servicing), the person responsible must be aware of all the instructions in the heat pump's installation manual as well as the technical specifications.

Under no circumstances install the equipment close to a source of heat, combustible materials or a building's air intake.

If installation is not in a location with restricted access, a heat pump protective grille must be fitted.

To avoid severe burns, do not walk on pipework during installation, repairs or maintenance.

To avoid severe burns, prior to any work on the refrigerant system, turn off the heat pump and wait several minutes before placing temperature and pressure sensors.

Check the refrigerant level when servicing the heat pump.

Check that the high and low pressure switches are correctly connected to the refrigerant system and that they turn off the electrical circuit if tripped during the equipment's annual leakage inspection.

Check that there is no trace of corrosion or oil stains around the refrigerant components.

1. GENERAL INFORMATION

When in use

Do not touch the vent during operation due to the risk of serious injury.

Do not leave the heat pump within reach of children due to the risk of injury caused by the heat exchanger fins.

Never start the equipment if there is no water in the pool or if the circulating pump is stopped.

Check the water flow rate every month and clean the filter if necessary.

When cleaning

1. Switch off the power supply to the device.
2. Close the water inlet and outlet valves.
3. Do not place anything in the openings of the water or air inlets/outlets.
4. Do not spray the appliance with excessive amounts of water.

During repairs

Carry out work on the refrigerant system in accordance with current safety regulations.

Brazing should be performed by a qualified welder.

When replacing a defective refrigerant component, use only parts certified by our technical department.

When replacing pipework, only copper pipes conforming to Standard NF EN12735-1 may be used for repairs.

When pressure-testing to detect leaks:

- Use dehydrated nitrogen or a mixture of nitrogen and refrigerant.
- To avoid the risks of fire or explosion, never use oxygen or dry air.

The low and high side test pressure must not exceed 42 bar.

1.3 Water treatment

Poolex heat pumps for swimming pools can be used with all types of water treatment systems.

Nevertheless, it is essential that the treatment system (chlorine, pH, bromine and/or salt chlorinator metering pumps) is installed after the heat pump in the hydraulic circuit.

To avoid any deterioration to the heat pump, the water's pH must be maintained between 6.9 and 8.0.

2. DESCRIPTION

2.1 Package contents

At reception, please check that your package contains the following:

- The Poolex O'SPA Flow heat pump (with integrated circulation pump)
- 2 x 1" (inch) connectors for NETSPA basin
- 2x 1" (inch) to 32/38 mm hydraulic connections
- 2x stainless steel hose clamps
- 1x spa heater control relay
- 4x anti-vibration pads (directly mounted on the heat pump)
- This installation and operation manual

2.2 General characteristics

A Poolex heat pump has the following features:

- ▶ High performance with up to 80% energy savings compared to a conventional heating system.
- ▶ Clean, efficient and environmentally friendly R32 refrigerant.
- ▶ Reliable high output leading brand compressor.
- ▶ Wide hydrophilic aluminum evaporator for use at low temperatures.
- ▶ User-friendly intuitive control panel.
- ▶ Heavy duty shell, anti-UV treated and easy to maintain.
- ▶ CE certification.
- ▶ Designed to be silent.

2.3 Operating limits

Your O'SPA heat pump's performance is at its optimal when outside temperature is between 10°C and 43°C.

When outside temperature is between -7°C and 10°C, the O'SPA heat pump is useful to maintain the temperature within the hot tub. However, it is not suitable to heat up your hot tub alone when outside temperature is below 10°C. As such, it is recommended to use it with the SPA heater control relay (see paragraph 4.5) during the cold season.

Your hot tub must be correctly insulated to enable the O'SPA heat pump to function in an optimal way.

- The tub must be insulated.
- The piping must be insulated.
- The hot tub must be equipped with an insulating cover.

Heating an uninsulated pool is like turning on the heating with the window open.

2. DESCRIPTION

2.4 Technical characteristics

		O'Spa 34	O'Spa 54	O'Spa 74
Air ⁽¹⁾ 26°C	Heating power (kW)	3,30	5,06	7,10
Water ⁽²⁾ 26°C	Consumption (kW)	0,66	0,95	1,28
80% humidity	COP (Coeff. Of performance)	5,00	5,30	5,55
Air ⁽¹⁾ 26°C	Heating power (kW)	2,95	4,60	6,40
Water ⁽²⁾ 38°C	Consumption (kW)	0,78	1,14	1,42
80% humidity	COP (Coeff. Of performance)	3,80	4,05	4,50
Air ⁽¹⁾ 15°C	Heating power (kW)	2,28	3,56	5,00
Water ⁽²⁾ 26°C	Consumption (kW)	0,63	0,89	1,18
70% humidity	COP (Coeff. Of performance)	3,60	4,00	4,25
Air ⁽¹⁾ 15°C	Heating power (kW)	2,11	3,25	4,65
Water ⁽²⁾ 38°C	Consumption (kW)	0,75	1,08	1,37
70% humidity	COP (Coeff. Of performance)	2,75	3,00	3,40
Air ⁽¹⁾ 5°C	Heating power (kW)	1,47	2,43	3,70
Water ⁽²⁾ 38°C	Consumption (kW)	0,70	0,97	1,45
70% humidity	COP (Coeff. Of performance)	2,10	2,50	2,55
Air ⁽¹⁾ 0°C	Heating power (kW)	1,20	2,05	3,10
Water ⁽²⁾ 38°C	Consumption (kW)	0,69	0,93	1,24
70% humidity	COP (Coeff. Of performance)	1,75	2,20	2,50
Air ⁽¹⁾ 35°C	Cooling capacity (kW)	2,00	2,75	3,90
Water ⁽²⁾ 27°C	Consumption (kW)	0,98	1,38	1,66
70% humidity	EER	2,05	2,00	2,35
Air ⁽¹⁾ 27°C	Cooling capacity (kW)	1,40	1,90	2,75
Water ⁽²⁾ 10°C	Consumption (kW)	0,74	1,03	1,28
70% humidity	EER	1,90	1,85	2,15
Air ⁽¹⁾ 15°C	Cooling capacity (kW)	1,45	2,00	2,90
Water ⁽²⁾ 5°C	Consumption (kW)	0,62	0,78	1,00
70% humidity	EER	2,35	2,55	2,90
Power supply	Single phase 220-240V ~ 50Hz			
Maximum power (kW)	1,30	1,80	2,55	
Maximum current (A)	6,50	9,00	12,08	
Operating ambient temperature	Heating : -10~43 / Cooling : 7~40			
Heating temperature range	10 °C ~ 40 °C			
Cooling temperature range	2 °C ~ 30 °C			
Unit dimensions L x W x H (mm)	520*490*390			620*490*420
Net weight of device (kg)	33	38	47	
Sound pressure level at 1m (dBA) ⁽³⁾	< 50		< 55	
Sound pressure level at 10m (dBA) ⁽³⁾	< 30		< 35	
Hydraulic connections (mm)	PVC 32 mm			
Heat exchanger (air side / water side)	Hydrophilic aluminum and copper tube with inner groove/ Titanium coil (9.52mm*3.5m)			
Water flow rate (m ³ /h) - integrated pump	1,40	2,15	3,00	
Compressor type	Rotary			
Refrigerant	R32			
Quantity of refrigerant (kg)	0,27	0,38	0,52	
Protection rating	IPX4			
Load loss (kPa)	25		30	
Control panel	Digital-display control panel			
Mode	Heating/Cooling/Auto			

The technical specifications of our heat pumps are provided for information purposes only. We reserve the right to make changes without prior notice.

¹ Ambient air temperature

² Initial water temperature

³ Noise level at a distance of 10 m in accordance with international standards EN ISO 3741 and EN ISO 354

2. DESCRIPTION

2.5 Product dimensions

For OSPA 3kW and 5kW

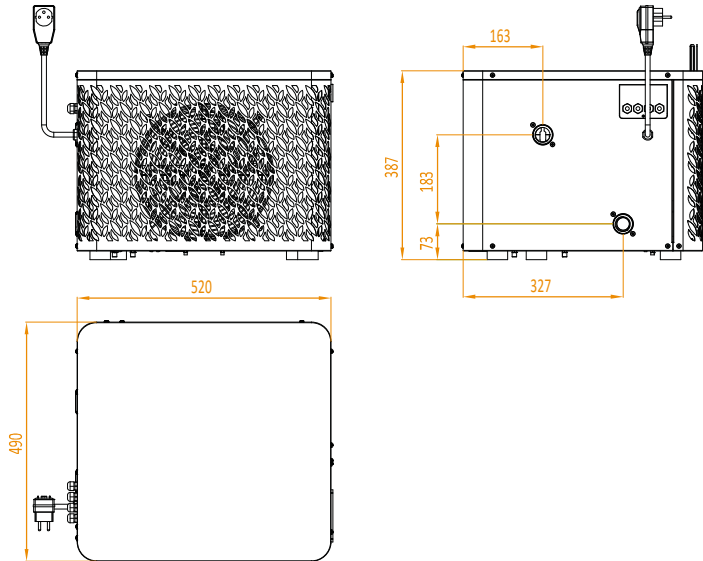

For OSPA 7kW

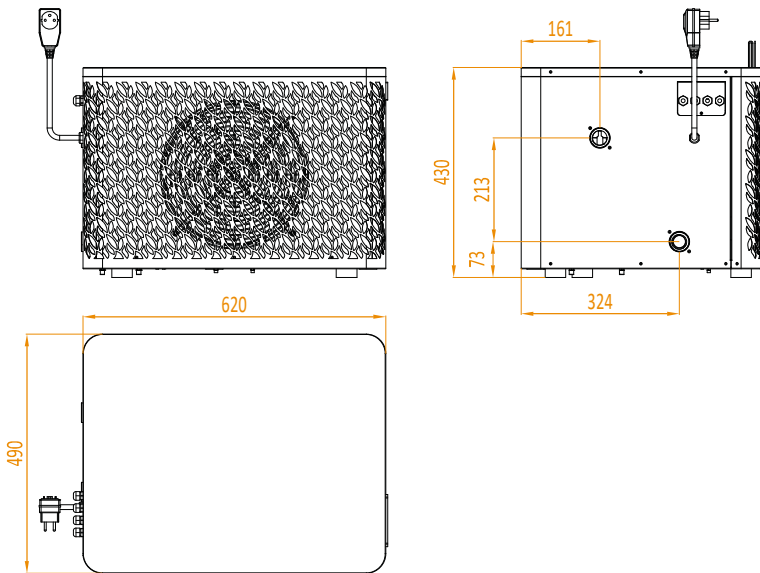

2. DESCRIPTION

2.6 Exploded view

For OSPA 3kW and 5kW

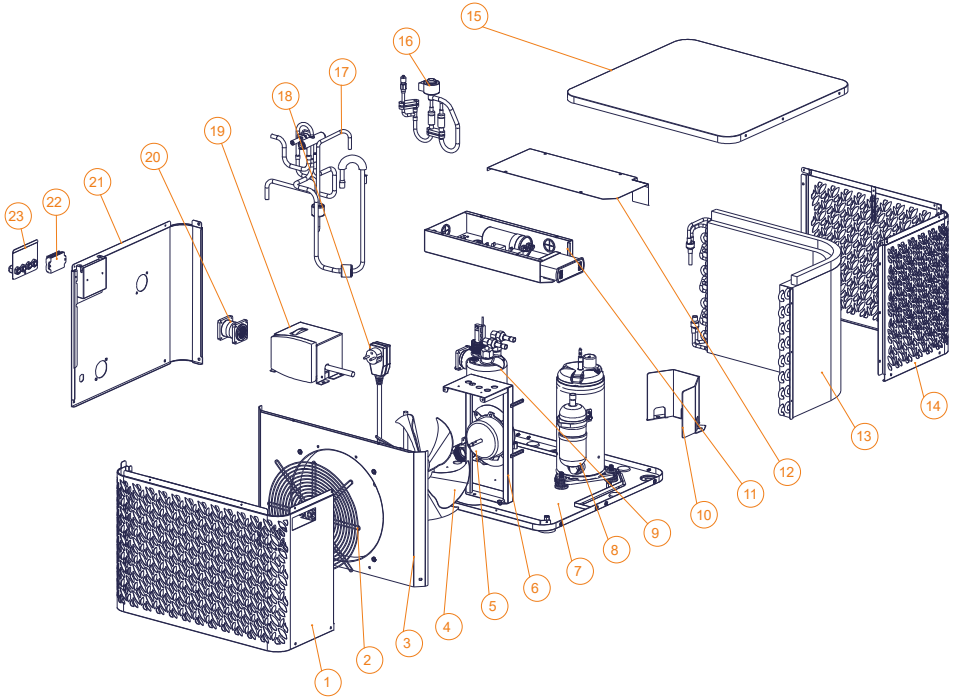

- | | |
|----------------------------|--------------------------|
| 1. Front panel | 13. Fin heat exchanger |
| 2. Fan grill | 14. Back panel |
| 3. Air deflector | 15. Top cover |
| 4. Fan blade | 16. EEV |
| 5. Fan motor | 17. 4-way valve |
| 6. Fan motor bracket | 18. RCD |
| 7. Bottom plate | 19. Water pump |
| 8. Compressor | 20. Water pump connector |
| 9. Titanium heat exchanger | 21. Side panel |
| 10. Compressor baffle | 22. Terminal block |
| 11. Electrical box | 23. Junction box cover |
| 12. Electrical box cover | |

2. DESCRIPTION

For OSPA 7kW

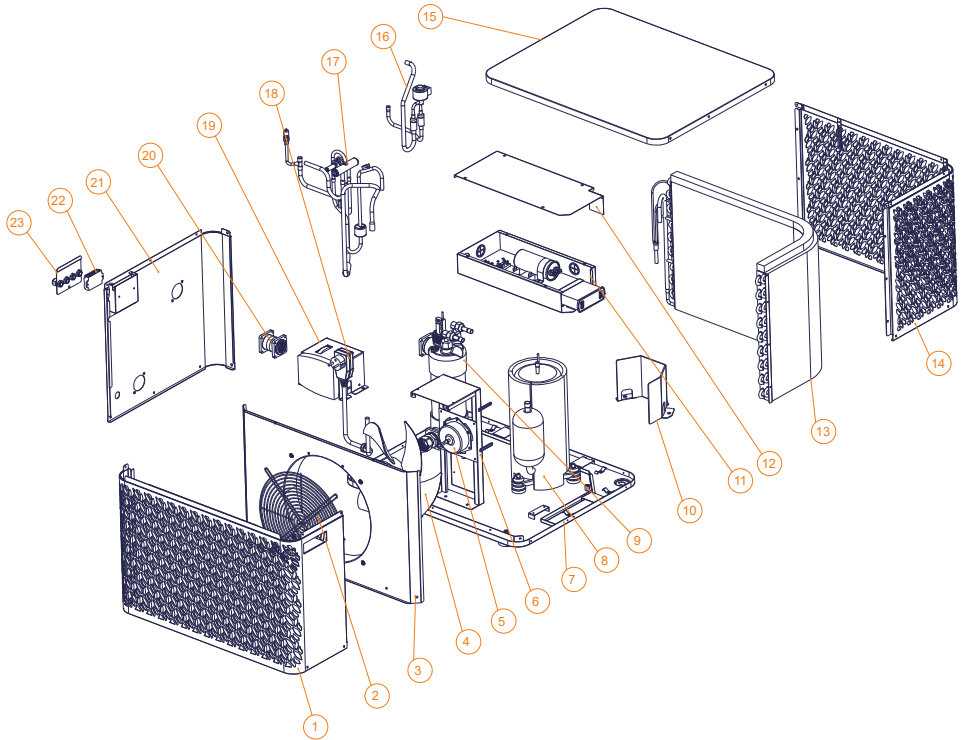

- | | |
|----------------------------|--------------------------|
| 1. Front panel | 13. Fin heat exchanger |
| 2. Fan grill | 14. Back panel |
| 3. Air deflector | 15. Top cover |
| 4. Fan blade | 16. EEV |
| 5. Fan motor | 17. 4-way valve |
| 6. Fan motor bracket | 18. RCD |
| 7. Bottom plate | 19. Water pump |
| 8. Compressor | 20. Water pump connector |
| 9. Titanium heat exchanger | 21. Side panel |
| 10. Compressor baffle | 22. Terminal block |
| 11. Electrical box | 23. Junction box cover |
| 12. Electrical box cover | |

3. INSTALLATION

To install the heat pump only the hydraulic circuit and the power need to be connected.

3.1 Location

Standard NF C 15-100 recommends installing the heat pump at least 2.5 meters from the pool. However, thanks to the differential circuit breaker, you can also choose to install it closer: Leave at least 1.50 m in front of the heat pump and 30 cm of empty space to the sides and rear of the heat pump..

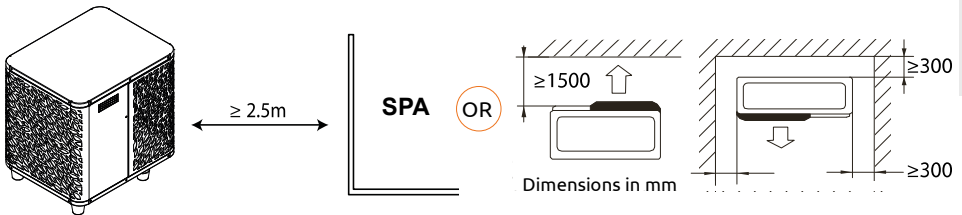

- Do not place anything within 1.5m of the front of the heat pump.**
- Do not place any obstacles on top or in front of the device!**
- Do not use the heat pump as a step to access the spa or the pool.**
- Do not step on the heat pump.**

Please respect the following rules when choosing the heat pump's installation location

1. The location must be easily accessible for optimal operation and maintenance.
2. The device must be installed on the ground, ideally on a level concrete slab. Ensure that the ground is sufficiently stable and it can support the weight of the device.
3. Check that there is enough air flow, that the air exhaust is not directed towards the windows of neighbouring buildings, and that exhaust air cannot return to the intake. In addition, ensure that there is enough space around the device to perform servicing and maintenance.
4. The device must not be installed in locations susceptible of being exposed to oil, flammable gas, corrosive agents, sulphur compounds, or near high frequency devices.
5. Do not install the device near to roads or footpaths to avoid mud splattering.
6. To avoid disturbing neighbours, make sure to install the device facing away from areas sensitive to noise.
7. Keep out of the reach of children insofar as possible.

3. INSTALLATION

3.2 Installation diagram

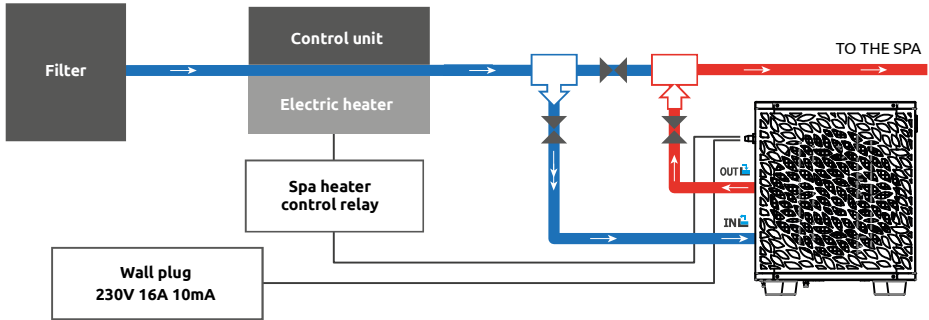

The filter located upstream of the heat pump must be regularly cleared so that the water in the system is clean, thus avoiding the operational problems associated with dirt or clogging in the filter. (By-pass ref. : SP-HLKITBYPASS)

Note: The circulation pump is integrated and operates automatically.

3.3 Hydraulic connection

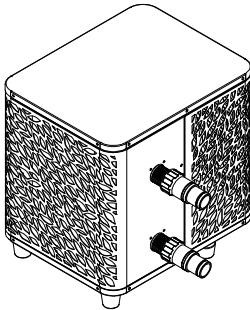

Step 1

Screw the connectors for heat pump

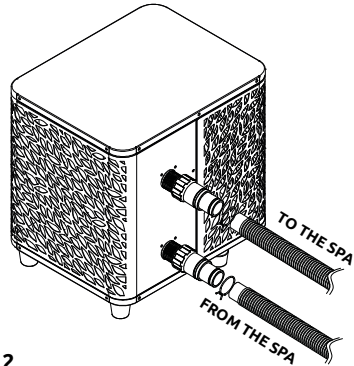

Step 2

Connect the water inlet and outlet

3.4 Electrical connection

Pump's power plug integrates a 10mA differential circuit breaker.

Regularly test the correct operation. In the event of successive triggering or doubts contact the after-sales service.

Before plugging in your heat pump, please ensure the electrical socket is properly grounded and protected from rain as well as water projections.

Press the RESET button to start the O'SPA heat pump. The power indicator lights up in red: the heat pump is on.

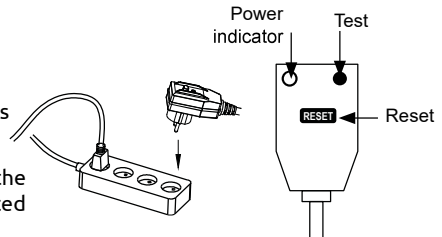

3. INSTALLATION

3.5 Operation

Use conditions

For the heat pump to operate normally, the ambient air temperature must be between 10°C and 43°C when it is used alone or between -7°C and 10°C when used with the SPA heater.

Advance notice

Prior to starting the heat pump, please:

- Check that the equipment is in a stable position.
- Check that your electrical installation is in good working condition.
- Check that the hydraulic connections are properly tightened and there is no water leakage.
- Remove any object that is not required around the equipment and all tools.

Operation

1. Connect the power supply to the device.
2. Activate the device's electrical supply protection (differential switch situated on the power cable).
3. Start the heat pump.
4. Select the desired temperature using one of the modes appearing on the control panel.
5. The heat pump's compressor will start shortly after.

And you just need to wait for the target temperature to be reached.



WARNING: Under normal conditions, a suitable heat pump can heat up the tub water by 1°C to 2°C per hour. It is therefore normal that you do not feel any difference in temperature at the outlet level when the heat pump is on.

A heated tub must be covered and insulated to avoid any heat loss.

Good to know: restart after power failure

After a power failure or a usual interruption, turn the power back on, the system is on sleep mode. Restart the differential plus and switch on the heat pump.

4. USE

4.1 Control panel

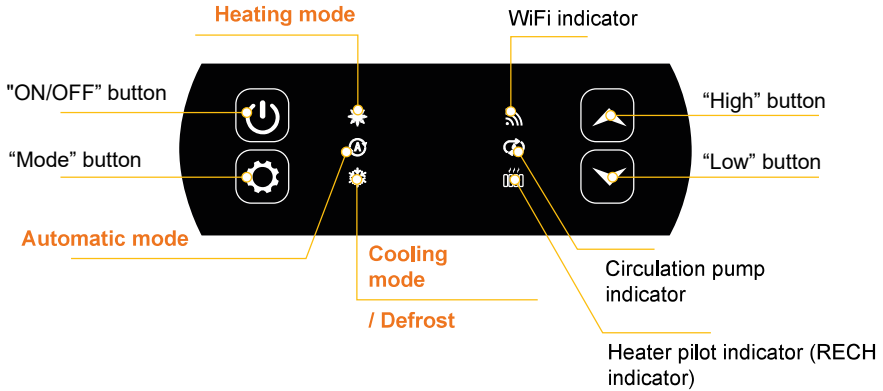

4.2 Heating / Cooling / Automatic mode



Before use, ensure that the filtration pump is working and that water is circulating through the heat pump.

Prior to setting your required temperature, you must first select an operating mode for your remote.



Heating mode

Select the heating mode if you want to heat up the tub water with the heat pump.



Cooling mode

Select the cooling mode if you want to heat up the tub water with the heat pump.



Automatic mode



Select the automatic mode if you want to let the heat pump switch to the correct mode in a smart way according to the target temperature.

4. USE

4.3 Heat pump operating mode selector

By default, the heat pump is in heating mode.

To change the mode of use, when the heat pump is ON:

- Press the button  for **3s**, the heat pump will then switch to cooling.
- Press the button again  for **3s**, the heat pump will then switch to automatic.
- Press the button again  for **3s**, the heat pump will then switch heating.

The different modes thus form a cycle:



Good to know:

The heat pump can take several minutes to change operating mode in order to preserve the refrigerant fluid.

The maximum set temperature is 40°C.

4.4 Functions overview

The indicators to the right of the control panel indicate the O'SPA heat pump's other functions.



WiFi indicator

Indicates your Wifi connection status.
Flashes during pairing (see paragraph 4.9 "Pairing the heat pump"). It remains on when a connection is active.



Circulation pump indicator

On when the circulation pump is active.



Heater pilot indicator

The RECH light is on when the heater is active:

- Fixed light in automatic mode,
- Flashing in manual mode.

4. USE

4.5 Using the SPA heater control relay

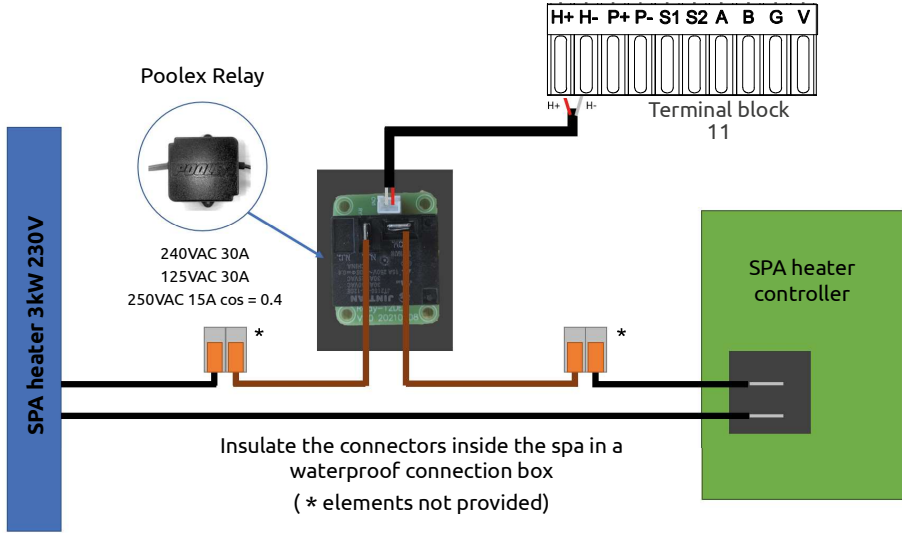

The SPA heater SPAWER driver system consists of a power relay (230V50Hz / 20A) which plugs into the heater phase wire (between the SPA heater controller output and the heater itself).

This relay is controlled by the heat pump control box either automatically or manually (boost).

As such, for the system to function properly, it is imperative to set the desired SPA water temperature to maximum on the SPA control screen and program the filtration time. In this way, the actual temperature setting will now be done on the PAC or via the Smartphone app.

- **In automatic spa heater mode:** When weather conditions become difficult for the heat pump (C26 setting: outside temperature below 15°C by default; adjustable from 0 to 20°C) and the desired bathing temperature is 5°C higher than the measured water temperature (C27 setting), the heater control relay is triggered. Thus the heating uses the electric heater of the SPA in addition to the heat pump in order to reach the desired temperature.

- **In manual spa heater mode:** Regardless of the weather conditions, as soon as the temperature difference between the set point and the measurement is greater than 2°C (C28 setting), the relay is triggered. Thus the heating uses the electric heater of the SPA in addition to the heat pump in order to reach the desired temperature.

For information, in automatic or cooling mode, the heater control option is inactive, it only operates in heating mode.

To use this relay:

Setting the **C32** setting = 1 to start the control (see advanced settings).

When the heat pump is on heating mode (automatic mode with heatin on): press the  button for 3 seconds to switch the heater from one mode to another (automatic or manual).

In automatic mode, the (RECH) indicator is fixed. In manual mode, the (RECH) indicator flashes.

4. USE

4.6 Downloading & installing the application «Poolex»

EN

About the Poolex app:

To control your heat pump remotely, you need to create a Poolex account.

The Poolex application lets you control your pool equipment remotely, wherever you are. You can add and control several devices at once. Appliances compatible with Smart Life or Tuya (depending on the country) are also compatible with the Poolex application.

With the Poolex application, you can share the devices you've set up with other Poolex accounts, receive real-time operating alerts and create scenarios with several devices, based on the application's weather data (geolocation essential).

Using the Poolex application also means taking part in the continuous improvement of our products.

iOS :

Scan or search for «Poolex» in the App Store to download the app:



Check the compatibility of your phone and the version of your OS before installing the application.

Android :

Scan or search for «Poolex» in the play to download the app:

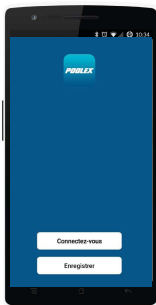

Check the compatibility of your phone and the version of your OS before installing the application.

4. USE

4.7 Setting up the application



WARNING: Before you begin, make sure you have downloaded the «Poolex» app, connected to your local WiFi network, and that your heat pump is electrically powered and running.

You'll need to create a «Poolex» account to control your heat pump remotely. If you already have a Poolex account, please log in and go directly to step 3.

Step 1: Click on «**Create new account**» and choose to register by «**Email**» or «**Phone**,» where a verification code will be sent to you.

Enter your email address or phone number and click «**Send verification code**».

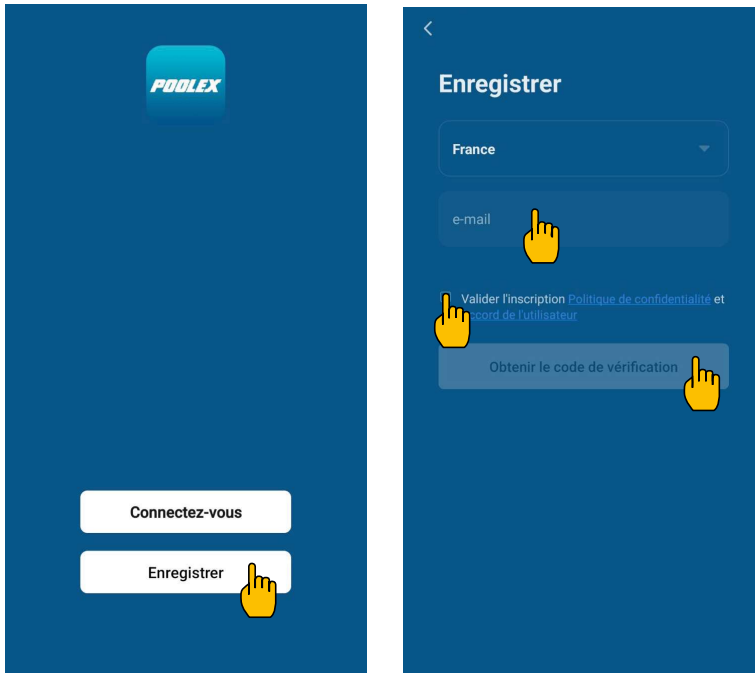

Step 2: Enter the verification code received by email or phone to validate your account.

Congratulations, you now belong to the “Poolex” community.

4. USE

Step 3 (recommended): Add an object by clicking "...” and then “Add Object”. Enter a name («Pool» for example), then click “Done”.

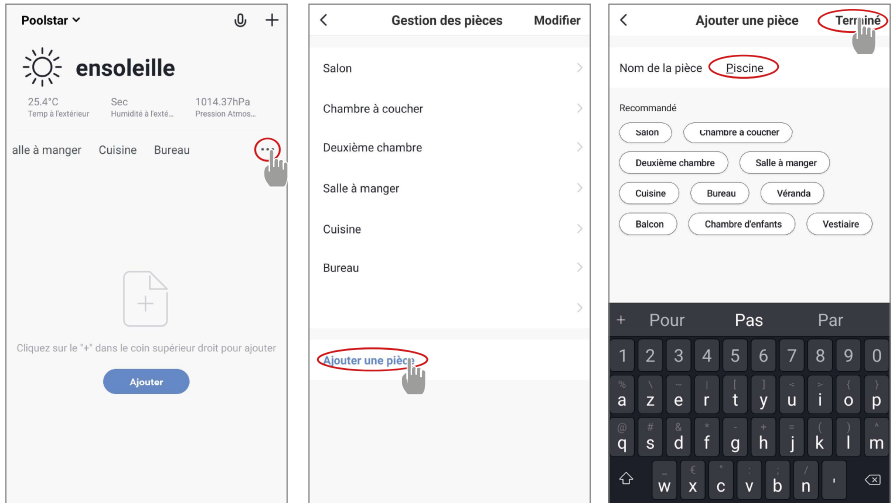

Step 4: Now add a device to your “Pool”.

Click “Add” or “+” and then “Large appliances...” followed by “Water heater”.

At this point, leave your smartphone on the “Add” screen and go to the pairing step for your control box.

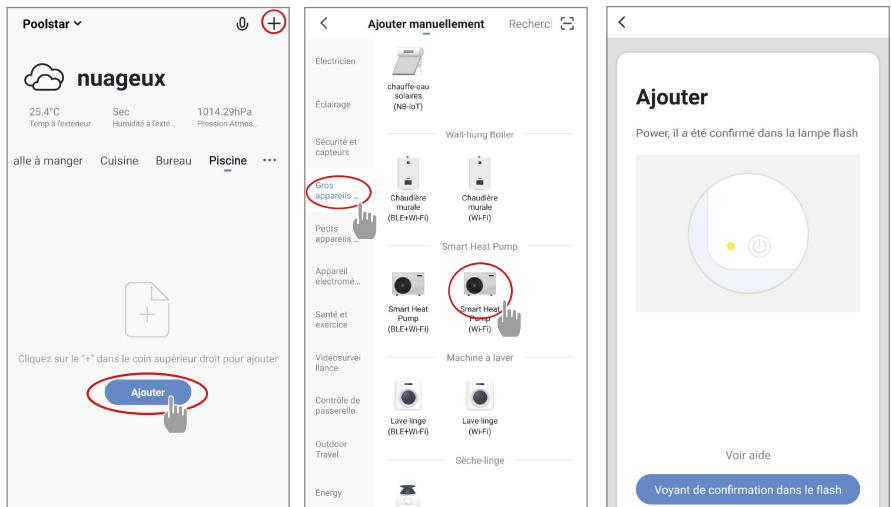

4. USE

4.8 Pairing the heat pump

Step 1: Now start the pairing.

Choose your home WiFi network, enter the WiFi password and press "Confirm".





WARNING: The «Poolex» application only supports 2.4Ghz WiFi networks.

If your WiFi network uses the 5GHz frequency, go to the interface of your home WiFi network to create a second 2.4GHz WiFi network (available for most Internet boxes, routers and WiFi access points).

Step 2: Activate the pairing mode on your heat pump according to the following procedure:

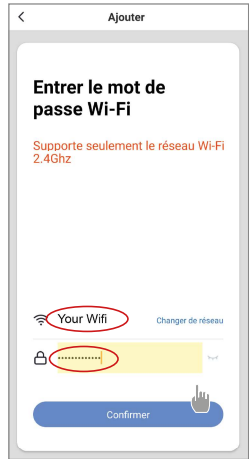
The procedure depends on the model of your control panel:



With the heat pump on, press on  for 5 seconds to start the WiFi pairing. The WiFi logo flashes.

The pairing is successful, the "WiFi" logo remains fixed, you can rename your Poolex heat pump then press "Done".

Congratulations, your heat pump can now be controlled from your smartphone.

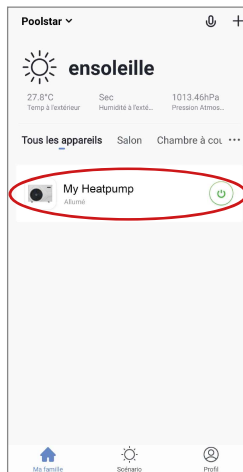
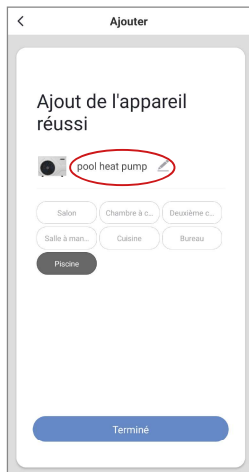

4. USE

4.9 Controlling

User interface

- 1 Current pool temperature
- 2 Temperature set point
- 3 Current operating mode
- 4 Switch the heat pump on/off
- 5 Change the temperature
- 6 Change operating mode
- 7 Set the operating range



Heat pump operating mode selector

You can choose between Auto, Heating or Cooling modes.

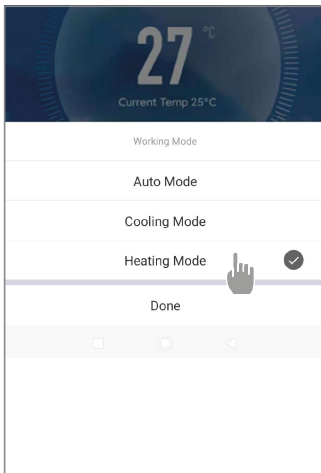

Available modes

- Automatic
- Cooling
- Heating

4. USE

About the settings

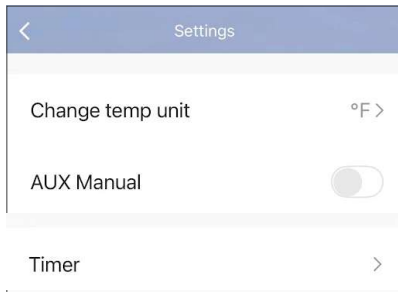

Choice of temperature unit (°C or °F)

Activating the manual mode (or automatic) for the SPA heater

Timer

Setting up the heat pump operating range

Step 1: Create a time schedule, choose the time, the day(s) of the week concerned, and the action (switch on or switch off), then save.

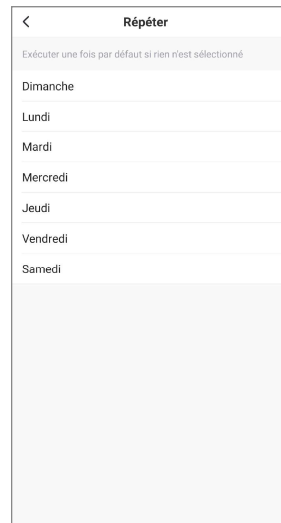
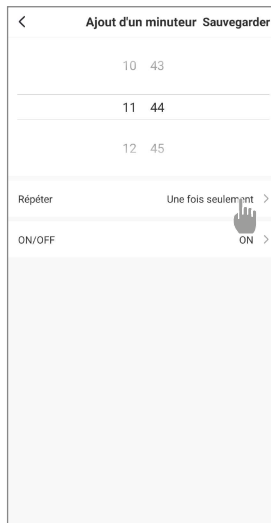
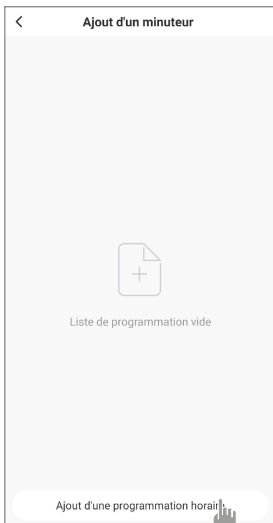

Step 2: To delete a time slot, press and hold the time slot.

4. USE

4.10 Status values

The system's settings can be checked and adjusted via the remote control by following these steps

Step 1: Press on  until you enter the settings verification mode.

Step 2: Press on  and  to see the parameters.





Step 3: Press on  to select the setting to be viewed.

Parameters table

Parameters	Indication	Adjustment range	Comments
d0	Ambient temperature	-30°C - 105°C	Measured value
d1	Inlet water temperature	-30°C - 105°C	Measured value
d2	Outlet gaz temperature	-20°C - 127°C	Measured value
d3	Coil temperature	-30°C - 105°C	Measured value
d4	Compressor	ON/OFF	Measured value
d5	Ventilator	ON/OFF	Measured value
d6	4-way valve	ON/OFF	Measured value
d7	High pressure protection	--	Measured value
d8	Low pressure protection	--	Measured value
d9	Flow sensor	ON/OFF	Measured value
d10	Outlet water temperature	-30°C - 105°C	Valeur mesurée
d11	Suction gaz temperature	-30°C - 105°C	Valeur mesurée
d12	Target open step	60 ~ 480	Valeur mesurée
d13	Actual open step	60 ~ 480	Valeur mesurée

4.11 Forced defrosting

When the heat pump is operating in heating mode:

1. Switch off the heat pump,
2. Press the button  for 3 seconds to access the parameter modification page.
3. Change parameter C34: by default, it is set to 0. Set it to 1 to activate it.
 - a. Select the desired parameter using the up and down arrows.
 - b. Press  to select the parameter to be adjusted.
 - c. Use the arrows to change the value of the parameter.
 - d. Press  to confirm, then exit the page.
4. Switch on the heat pump. The heat pump starts defrosting and the icon  flashes.
When defrosting is complete, the heat pump restarts in heating mode.

4. USE

4.12 Advanced settings



WARNING: This operation is used to assist servicing and future repairs.

The default settings should only be modified by an experienced professional person.

The system's settings can be checked and adjusted via the remote control by following these steps. Caution, some settings cannot be modified, check the settings table for more information.

Step 1: Switch off the heat pump.

Step 2: Keep pressing  for 3 seconds to access the settings.

Step 3: Select the desired setting using the down and up arrows

Step 4: Press on  to select the setting to be adjusted.

Step 5: Press on  to save the new value.

Parameters	Indication	Adjustment range	Default V.	
C0	Setting inlet water temp in heating mode	10°C~40°C	38°C	
C1	Water temp difference for restart in heating mode	0°C~3°C	0°C	
C2	Auto restart (0-without, 1-with)	0~1	1	
C3	Protection setting for too high discharge temp	30°C~120°C	115°C	
C4	Max. inlet water setting temp in heating mode	30°C~60°C	40°C	
C5	Min. inlet water setting temp in heating mode	5°C~30°C	10°C	
C6	Difference water temp to stop in heating mode	1°C~3°C	1°C	
C7	Setting inlet water temp in cooling mode	2°C~30°C	23°C	
C8	Water temp difference for restart in heating mode	0°C~3°C	1°C	
C9	Difference water temp to stop in cooling mode	0°C~3°C	0°C	
C10	Max. inlet water setting temp in cooling mode	20°C~35°C	30°C	
C11	Min. inlet water setting temp in cooling mode	2°C~18°C	2°C	
C12	Protection setting for too low ambient temp	-25~20°C	-10°C	
C13	Protection setting for too high ambient temp when heating	35~68°C	43°C	
C14	Protection temp difference for ambient temp	1~10°C	1°C	
C15	Water outlet temperature compensation in heating mode	-9°C~9°C	0°C	
C16	Cooling mode water outlet temperature compensation	-9°C~9°C	0°C	
C17	Selecting the inlet/outlet overtemperature protection function	0 (deactivated) /1 (activated)	0	
Only visible if C17=1	C18	Input/output water overtemperature protection setting	35°C~80°C	43°C
	C19	Inlet/outlet overtemperature protection hysteresis	1°C~10°C	2°C
C20	Selection of antenna ambient temperature differential overprotection function	0 (deactivated) /1 (activated)	0	

4. USE

Parameters	Indication	Adjustment range	Default V.	
Only visible if C20 = 1	C21	Difference between ambient temperature and coil temperature $\Delta T1$	0°C ~ 50°C	20°C
	C22	Difference between ambient temperature and coil temperature $\Delta T2$	0°C ~ 50°C	16°C
	C23	Difference between ambient temperature and coil temperature $\Delta T3$	0°C ~ 50°C	12°C
	C24	Difference between room temperature and coil temperature $\Delta T4$	0°C ~ 50°C	8°C
	C25	Detection of compressor start time based on difference between ambient temperature and coil temperature	5s ~ 60s	10s
C26	AUX turn On ambient temp in heater Auto mode	-5°C ~ 20°C	15°C	
C27	AUX water temp difference for restart in heater Auto mode	1~5°C	5°C	
C28	AUX water temp difference for restart in Manual mode	1~5°C	2°C	
C29	Setting inlet water temp in Auto mode	2°C~40°C	38°C	
C30	PUMP parameter	0 (deactivated) /1 (activated)	1	
C31	PUMP working interval of time	30-90 min	60 min	
C32	AUX parameter	0 (deactivated) /1 (activated)	1	
C33	Protection setting for too high ambient temp when cooling	25-60°C	43°C	
C34	Manual defrosting	0 (deactivated) /1 (activated)	0	
H0	Defrosting mode activation timer	1~240min	40 min	
H1	Defrosting mode max. duration	1~25min	8 min	
H2	Defrosting exit coil temp	1~25°C	12°C	
H3	Defrosting entry coil temp	-20~20°C	-1°C	
H4	Temp difference between defrosting entry ambient temp and coil temp	0~15°C	8°C	
H5	Min. Ambient temp to entry defrosting	0~20°C	20°C	
P1	CN19 function selection	0 : no function 1 : high pressure switch (reserved) 2-3 : (reserved)	0	
P2	Select degrees Celsius °C or Fahrenheit °F	0 : °C; 1 : °F	0	

When OFF, pressing on  for 5 seconds resets the settings to factory settings.

5. MAINTENANCE AND SERVICING

5.1 Maintenance, servicing and winterizing



WARNING: Before undertaking maintenance work on the unit, ensure that you have disconnected the electrical power supply.

Cleaning

The heat pump housing must be cleaned with a damp cloth. Using detergents or other household cleaning products may degrade the surface of the housing and affect its integrity.

The evaporator at the rear of the heat pump must be carefully cleaned with a vacuum cleaner and soft brush attachment.

Annual maintenance

The following operations must be undertaken by a qualified person at least once a year.

- Carry out safety checks.

- Check the integrity of the electrical wiring.

- Check the earthing connections.

Wintering

Your heat pump is designed to operate in all weather. However, if you winterize your SPA, it is not recommended to leave the heat pump outside for long periods of time (eg over winter). After draining down the SPA for the winter, uninstall the heat pump and store it in a dry place.

6. REPAIRS



WARNING: Under normal conditions, a suitable heat pump can heat up the tub water by 1°C to 2°C per hour. It is therefore normal that you do not feel any difference in temperature at the outlet level when the heat pump is on.

A heated tub must be covered and insulated to avoid any heat loss.

6.1 Breakdown and faults

In the event of a problem, the heat pump's screen displays an error code instead of temperature indications. Please consult the table below to find the possible causes of a fault and the actions to be taken.

Code	Fault Name	Action
E0	Ambient temp too high or too low	Shutdown protection
E1	Inlet water temp sensor failure	Shutdown protection
E2	Ambient temp sensor failure	Shutdown protection
E3	Too high discharge gas temp	Shutdown protection
E4	Discharge temp sensor failure	Shutdown protection
E5	Coil temp sensor failure	Shutdown protection
E6	Water flow protection	Shutdown protection
E7	Suction gas temperature sensor failure	Shutdown protection
E18	Outlet water temperature sensor failure	Shutdown protection

7. WARRANTY

7.1 General terms and conditions of warranty

Poolstar guarantees the original owner against material defects and manufacturing defects of Poolex heat pump O'Spa for a period of **two (2) years**.

The warranty enters into force on the first billing date.

This warranty does not apply to the following situations:

- **Malfunction** or damage resulting from installation, use or repair that does not comply with the safety instructions.
- **Malfunction** or damage deriving from an unsuitable chemical environment of the swimming pool.
- **Malfunction** or damage resulting from conditions unsuitable for the intended use of the device.
- Damage resulting from negligence, accident, or force majeure.
- **Malfunction** or damage deriving from the use of unauthorized accessories.

Repairs undertaken during the warranty period must be approved before being carried out by a qualified technician. This warranty is void in the event of repairs to the device made by individuals which have not been authorised by Poolstar.

The parts under warranty shall be replaced or repaired at the discretion of Poolstar. Faulty parts must be returned to us during the warranty period in order to be covered. The warranty does not cover unauthorized labor or replacement costs. Delivery costs for returning the faulty part are not covered by the warranty.

Dear customer,

A question? A problem? Or simply register your warranty, find us on our website:

<https://assistance.poolstar.fr/>

Thank you for your trust and support. Happy bathing!

Your personal information is processed in accordance with the French Data Protection Act of 06 January 1978 and will not be shared with 3rd parties.

8. ANNEX

8.1 Wiring diagram OSPA 3kW & 5kW

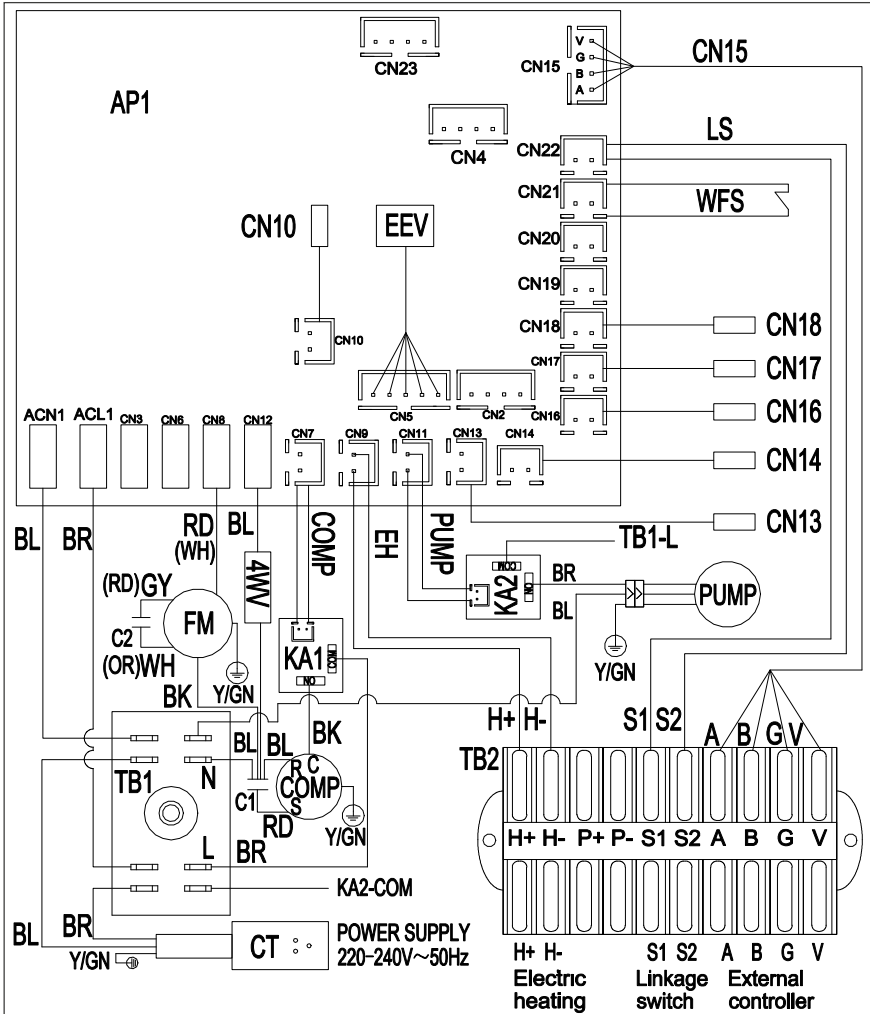

KA1 KA2	Relay	WFS	Water flow switch(E06)	WH	White
AP1	Main control board	CN10	Exhaust temperature(E04)	GY	Grey
FM	Fan motor	CN13	Coil temperature(E05)	BR	Brown
COMP	Compressor	CN14	Ambient temperature(E02)	BL	Blue
EEV	Electronic Expansion Valve	CN16	Inlet water temperature(E01)	RD	Red
4WV	Four-way valve	CN17	Outlet water temperature(E18)	BK	Black
PUMP	Water circulating pump	CN18	Suction temperature(E07)	Y	Yellow
EH	Electric Heating	LS	Linkage switch	GN	Green
C1	Compressor capacitor	CN15	External controller	CT	Leakage protection plug
C2	Fan motor capacitor	OR	Orange	TB1 TB2	Terminal Blocks

8. ANNEX

8.2 Wiring diagram OSPA 7kW

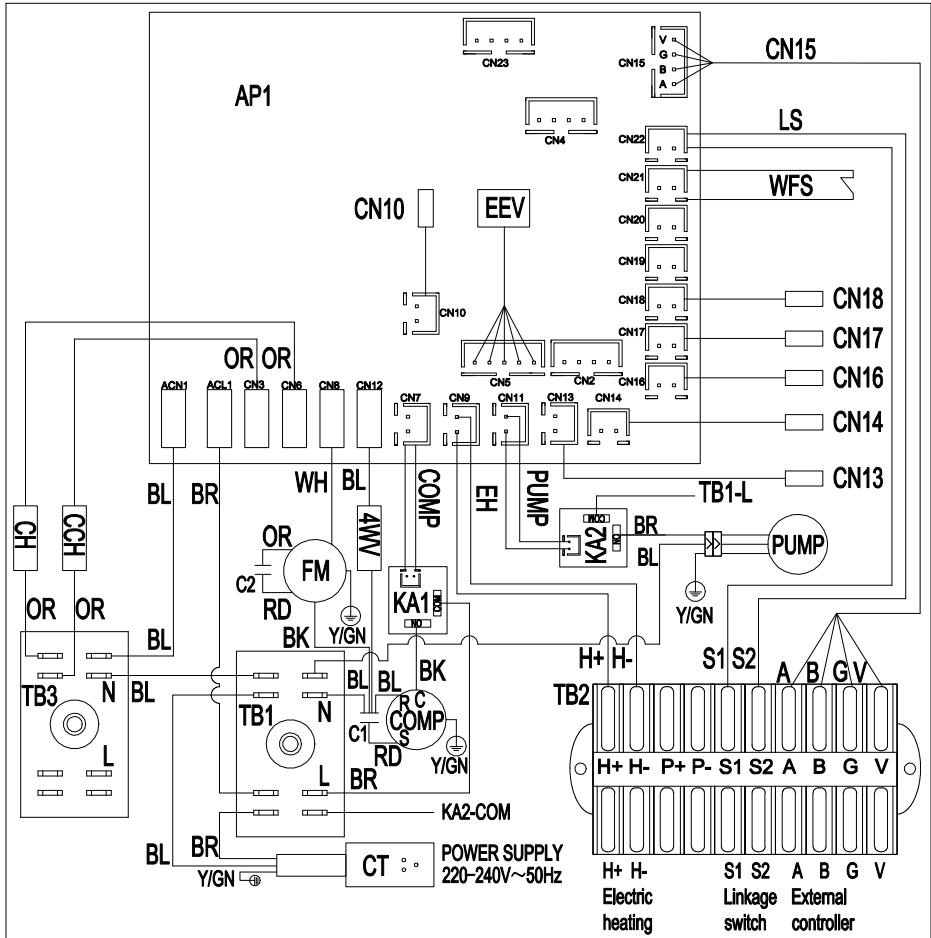

CCH	Compressor crankshaft heater
CH	Chassis heater
KA1,2	Relay
AP1	Main control board
FM	Fan motor
COMP	Compressor
EEV	Electronic Expansion Valve
4WV	Four-way valve
PUMP	Water circulating pump
EH	Electric Heating
C1	Compressor capacitor
C2	Fan motor capacitor

WFS	Water flow switch(E06)
CN10	Exhaust temperature(E04)
CN13	Coil temperature(E05)
CN14	Ambient temperature(E02)
CN16	Inlet water temperature(E01)
CN17	Outlet water temperature(E18)
CN18	Suction temperature(E07)
LS	Linkage switch
CN15	External controller
CT	Leakage protection plug
TB1,2,3	Terminal Blocks

WH	White
OR	Orange
BR	Brown
BL	Blue
RD	Red
BK	Black
Y	Yellow
GN	Green

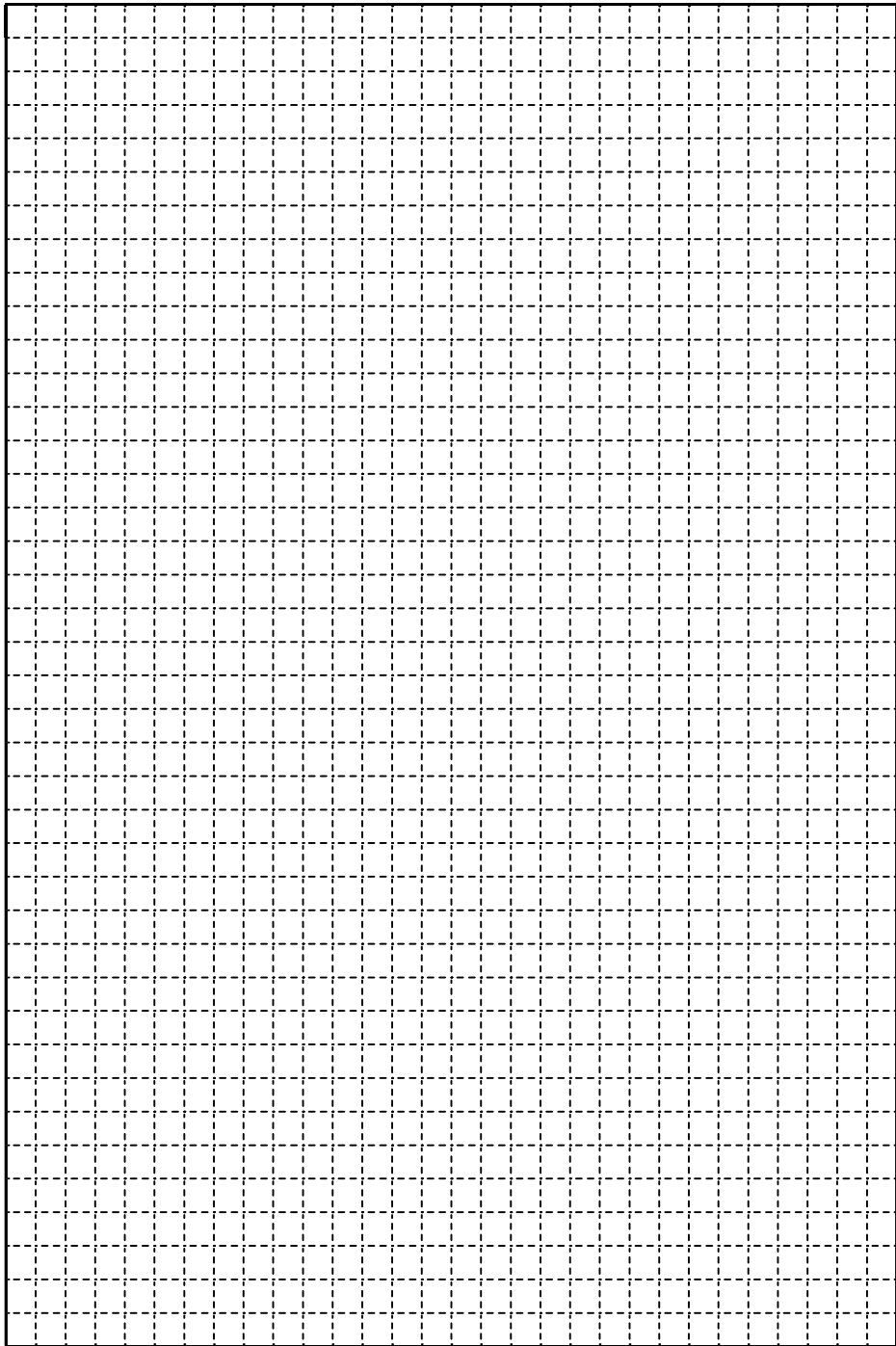

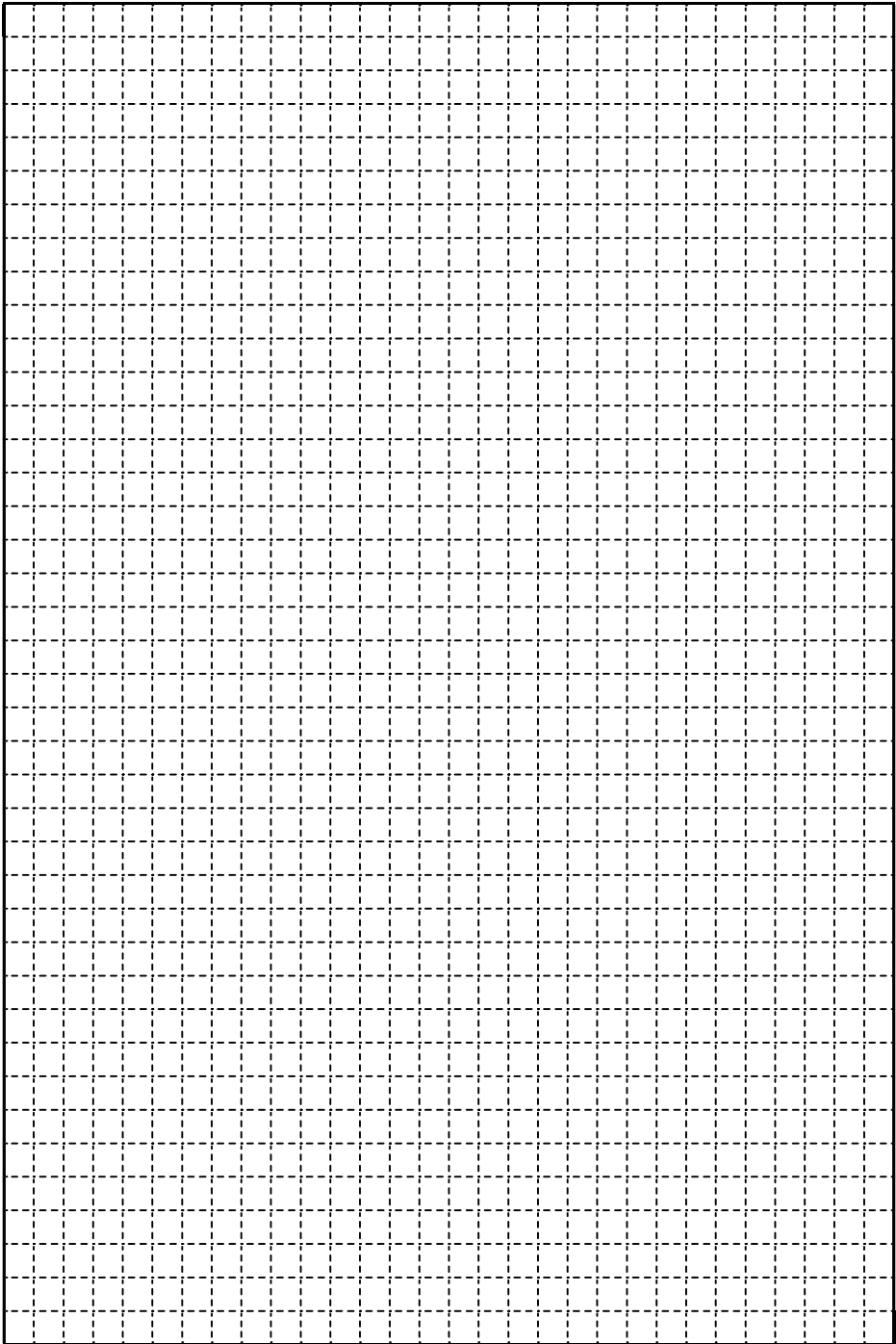

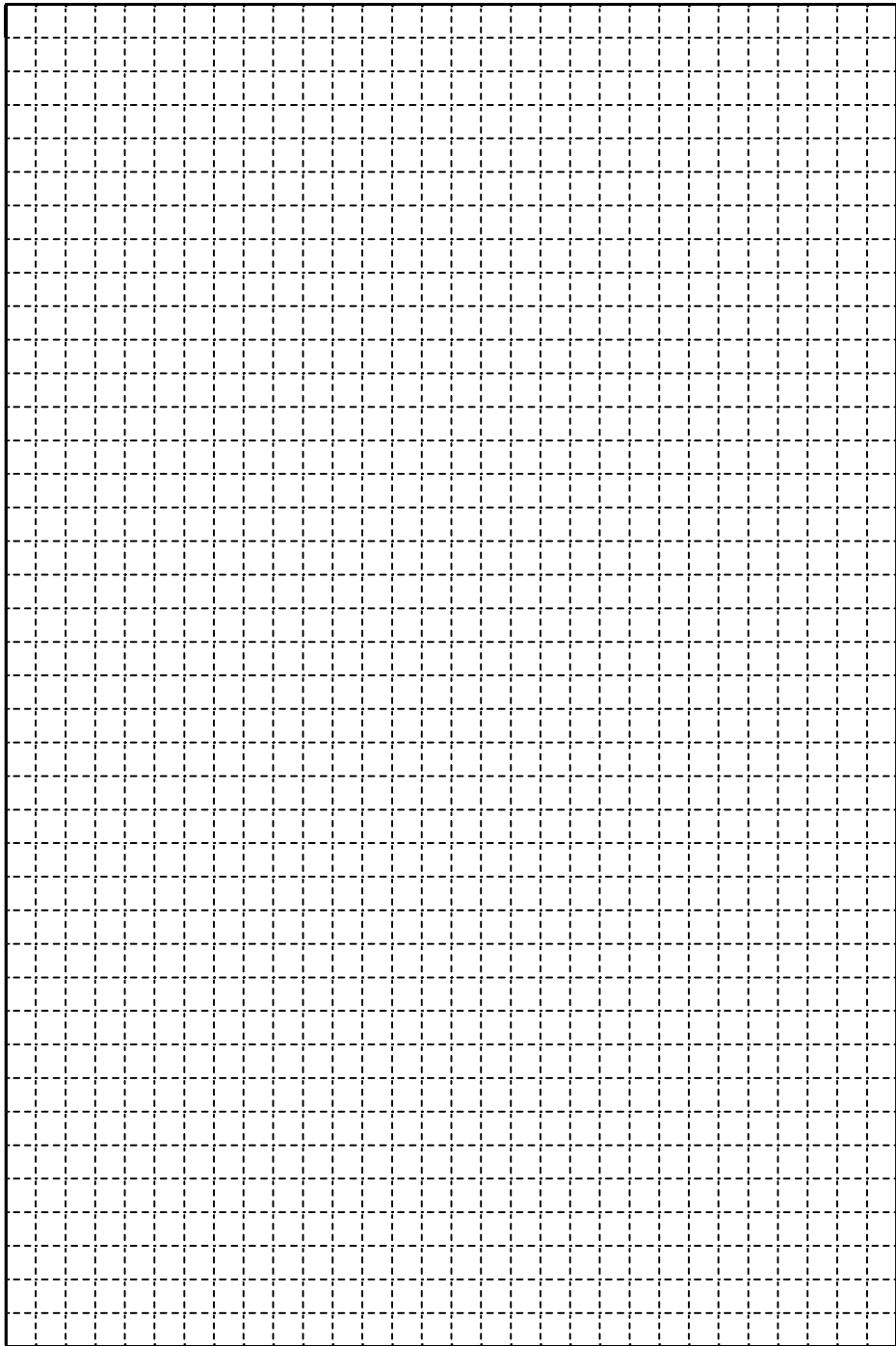

POOLEX



Assistance technique - Technical support -
Asistencia técnica - Assistenza tecnica -
Technische unterstützung - Technische bijstand

www.assistance.poolstar.fr
contact@poolstar.fr

Poollex is a brand of the group :

